

# SAND FILTERS

## MAGNUM BOBBIN SIDE MOUNT

### FIBREGLASS COMMERCIAL SAND FILTERS

- Filter tank made in polyester and non-corrosive fiberglass filaments winding.
- All internal components and connections are injection moulded PVC.
- Extra deep sand bed allows efficient filtration and backwashing.
- Designed to be assembled with butterfly valve and 2X3 oil pressure gauges are included.
- Large service opening (manhole) gives easy access to inside part of filter (optional)
- Sight glass made of top quality material (optional).
- Maximum operating pressure 4kg/cm<sup>2</sup>.
- UV resistant surface enables the filters to work in the direct sunlight.
- Best choice for an efficient water filtration for public swimming pool and industrial water treatment system.



### SPECIFICATIONS

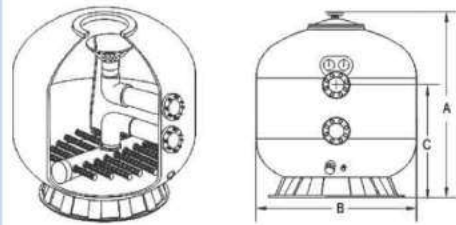

MODEL	FILTER Ø (mm)	CONNECTIONS (mm)	FLOW RATE (m <sup>3</sup> /h)	SAND WEIGHT (kg)	GRAVE WEIGHT (kg)	FILTER AREA (m <sup>2</sup> )
32002	1200	90	45	1250	300	1.13
32003	1400	110	61	1760	500	1.54
32004	1600	110	80	2450	750	2.01
32005	1800	160	101	3100	750	2.54
32006	2000	160	125	3800	1150	3.14
32007	2350	200	175	5275	1800	4.34
32008	2500	200	200	5950	2200	4.9

### TECHNICAL PARAMETERS

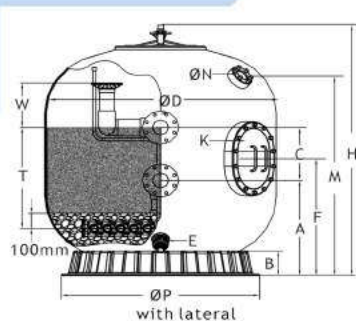

MODEL	Ø D (mm)	H (mm)	A (mm)	B (mm)	C (mm)	E (mm)	F (mm)	K (mm)	M (mm)	N (mm)	Ø P (mm)	T (mm)	W (mm)
32002	1200	1400	560	165	340	60	740	180*180	1150	80	980	600	300
32003	1400	1600	650	165	350	60	800	400*300	1250	80	1215	700	300
32004	1600	1750	680	215	450	60	875	400*300	1450	80	1450	800	320
32005	1800	1950	730	215	550	60	910	400*300	1650	80	1610	850	320
32006	2000	2140	800	240	550	60	1050	400*300	1700	80	1800	900	350
32007	2350	2350	940	240	600	60	1070	450*350	1800	80	2010	100	400
32008	2500	2450	960	240	600	60	1100	450*350	1900	80	2010	1050	400